

# PRODUCT INFORMATION PACKET

Model No: 145TTDR16014

Catalog No: GT2306

2 HP Close-Coupled Pump Motor, 3 phase, 3600 RPM, 200 V, 145JPV Frame, ODP  
JP Motors



### Nameplate Specifications

Output HP	<b>2 Hp</b>	Output KW	<b>1.5 kW</b>
Frequency	<b>60 Hz</b>	Voltage	<b>200 V</b>
Current	<b>6.5 A</b>	Speed	<b>3510 rpm</b>
Service Factor	<b>1.15</b>	Phase	<b>3</b>
Efficiency	<b>86.5 %</b>	Power Factor	<b>78.5</b>
Duty	<b>Continuous</b>	Insulation Class	<b>F</b>
Design Code	<b>B</b>	KVA Code	<b>L</b>
Frame	<b>145JPV</b>	Enclosure	<b>Drip Proof</b>
Thermal Protection	<b>No</b>	Ambient Temperature	<b>40 °C</b>
Drive End Bearing Size	<b>6206</b>	Opp Drive End Bearing Size	<b>6203</b>
UL	<b>Recognized</b>	CSA	<b>Y</b>
CE	<b>Y</b>	IP Code	<b>22</b>

### Technical Specifications

Electrical Type	<b>Squirrel Cage Inverter Rated</b>	Starting Method	<b>Line Or Inverter</b>
Poles	<b>2</b>	Rotation	<b>Reversible</b>
Resistance Main	<b>7.6 Ohms</b>	Mounting	<b>Rigid Base</b>
Motor Orientation	<b>Horizontal Or Shaft Down</b>	Drive End Bearing	<b>Ball</b>
Opp Drive End Bearing	<b>Ball</b>	Frame Material	<b>Rolled Steel</b>
Shaft Type	<b>JP</b>	Overall Length	<b>16.18 in</b>
Frame Length	<b>7.06 in</b>	Shaft Diameter	<b>0.875 in</b>
Shaft Extension	<b>7.31 in</b>	Assembly/Box Mounting	<b>F1 ONLY</b>
Connection Drawing	<b>A-EE7300</b>	Outline Drawing	<b>A-100132-706</b>

This is an uncontrolled document once printed or downloaded and is subject to change without notice. Date Created:20/01/2021



**THREE PHASE - SINGLE VOLTAGE  
MOTOR - CONDUIT BOX @ 'A'**

**TO REVERSE ROTATION:  
INTERCHANGE ANY TWO  
LINE LEAD CONNECTIONS.**

**TERMINAL BLOCK WHEN SPECIFIED**



**VIEW OF TERMINAL END**

**IF MOTOR HAS  
6 LEADS**

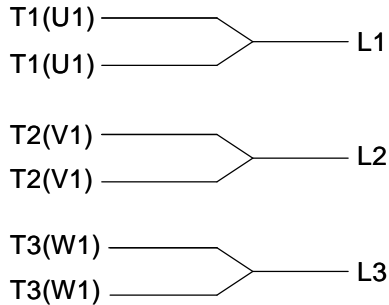

A-9806 DECAL

**OPTIONAL CORD  
CONNECTION**



DRAWING REVISION AB	REVISION BY JJB	DATE 06-27-2017
ECO ECO-0125361	APPROVED BY TB	DATE 06-27-2017
ECO DESCRIPTION <b>UPDATED TO CURRENT STANDARDS</b>		
<small>COPYRIGHT REGAL BELOIT AMERICA, INC. ALL RIGHTS RESERVED.                  PROPRIETARY AND CONFIDENTIAL INFORMATION - THIS DOCUMENT IS THE PROPERTY OF                  REGAL BELOIT AMERICA, INC. ("OWNER") AND CONTAINS OWNER'S PROPRIETARY                  INFORMATION. ANY PERSON, CORPORATION OR OTHER FIRM RECEIVING IT IS DEEMED,                  BY RECEIVING IT, TO AGREE THAT IT, AND/OR ANY PART OF IT, SHALL NOT BE DISCLOSED                  TO ANY PERSON, CORPORATION OR OTHER ENTITY, DUPLICATED, AND/OR USED, EXCEPT                  AS EXPRESSLY APPROVED IN WRITING IN ADVANCE BY OWNER. THIS DOCUMENT SHALL                  BE RETURNED TO OWNER UPON REQUEST. IT MAY BE SUBJECT TO CERTAIN                  RESTRICTIONS UNDER APPLICABLE EXPORT CONTROL LAWS AND REGULATIONS.</small>		



DRAWN BY DA
DATE 03-26-1993
APPROVED BY TB
DATE 03-26-1993
REFERENCE
THIRD ANGLE PROJECTION

Regal Beloit America, Inc.	
DESCRIPTION <b>CONNECTION DIAGRAM</b> EXTERNAL - SINGLE VOLTAGE - 3Ø MOTOR	
MATERIAL	PROCESS/FINISH
SIZE <b>A</b>	DRAWING NUMBER <b>EE7300</b>
SHEET <b>1 OF 1</b>	



Data Sheet

Date: 6/29/2017

145TTDR16014

Customer:



Submital

Attention:

FAREEDA DUDEKULA

Data @ 200 V

Submitted by:

Motor Load Data

Load	0%	25%	50%	75%	100%	115%	125%	LR
Current (Amps)	3.5	3.9	4.6	5.3	6.4	7.1	7.6	55.7
Torque (ft-lb)	0.00	0.71	1.50	2.20	3.0	3.5	3.8	9.0
RPM	3600	3580	3560	3540	3510	3,500	3495	0
Efficiency (%)		74.5	83.0	86.0	86.5	86.5	86.0	
P.F. (%)	10.0	37.0	58.0	71.0	78.5	81.0	83.0	64.5

Motor Speed Data

	LR	Pull-Up	BD	Rated	Idle
Speed (rpm)	0	1500	2570	3510	3600
Current (Amps)	55.7	50.1	37.3	6.4	3.5
Torque (ft-lb)	9.0	11.0	12.8	3.0	0.00

Information Block

HP	2.0
Sync. RPM	3600
Frame	145
Enclosure	DP
Construction	TDR
Voltage	200 V
Frequency	60 HZ
Design	B
LR Code letter	L
Service Factor	1.15
Temp Rise @ FL	38 °C
Duty	CONT
Ambient	40 °C
Elevation	1,000 feet
Rotor/Shaft wkt	0.03 Lb-Fe
Rel Wdg	ZT224 DR
Sound Pressure @ 1M	68 dBA
VFD Rating	CONSTANT 2:1
Outline Dwg	A-100132-706
Conn. Diag	A-EEZ300
Additional Specifications:	
0	

EQUIV CKT (OHMS / PHASE)				
R1	R2	X1	X2	Xm
0.0000	0.0000	0.0000	0.0000	0.0000

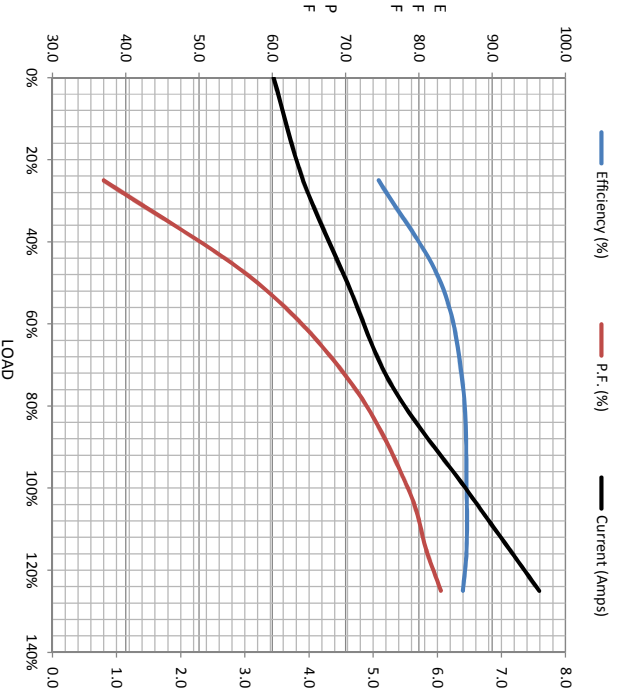

Speed - Torque Curve

